



Installation Instructions Bestop Gladiator Rock Rail

Vehicle Application:
Jeep® Gladiator 2020 - current
Part Number 44963

Installation Tips

Before you begin installing your new Bestop Bumper, please read all the instructions thoroughly.

If you have purchased other Bumper accessories, read all instructions carefully, as you may have to assemble these optional accessories before installing this bumper on your vehicle.

WARNING The manufacturer strongly recommends that this product be professionally installed.

WARNING Failure to carefully follow the electrical installation steps could result in severe electrical shock which could harm the installer and/or damage the vehicle.

WARNING This product is designed primarily to enhance the appearance and comfort of the vehicle. Do not rely in any way on the components of this product to protect the occupants within the vehicle, or to protect against injury or death in the event of an accident. Never operate the vehicle in excess of manufacturer's specifications.



WEAR SEAT BELTS AT ALL

CAUTION Safety glasses should be worn at all times when installing this product.

Tools		
 Safety Glasses	 Socket Wrench	 Torque Wrench
 2.5-4-5mm Allen Key or HexTool (Provided)	 10mm - 16mm - 18mm Wrenches	 8mm - 13mm - 16mm - 17mm - 18mm - 21mm (or 13/16") sockets

Installation Time
1-1/2 hours

Skill Level
<div style="display: flex; justify-content: space-around; align-items: center;"> <div style="border: 1px solid black; border-radius: 50%; width: 30px; height: 30px; display: flex; align-items: center; justify-content: center;">1</div> <div style="border: 1px solid black; border-radius: 50%; width: 30px; height: 30px; display: flex; align-items: center; justify-content: center;">2</div> <div style="border: 2px solid black; border-radius: 50%; width: 30px; height: 30px; display: flex; align-items: center; justify-content: center;">3</div> <div style="border: 1px solid black; border-radius: 50%; width: 30px; height: 30px; display: flex; align-items: center; justify-content: center;">4</div> </div> <p>3 - Moderately Diffi-</p>

Support
<p>We're here to help! Go to: https://www.bestop.com and click on Need Help?</p>
<p>https://www.bestop.com/video-library</p>



Installation Instructions Bestop Gladiator Rock Rail

Vehicle Application:
Jeep® Gladiator 2020 - current
Part Number 44963

Parts List

Sections 2 Attach Rock Rail

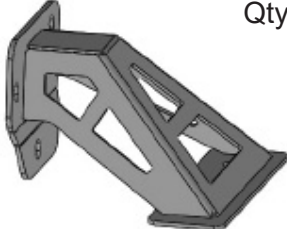

Rear Bumper RT
Part #200357939
Qty. 1



Rear Bumper RT
Part #200357944
Qty. 1



Rear Bumper LT
Part #200357933
Qty. 1

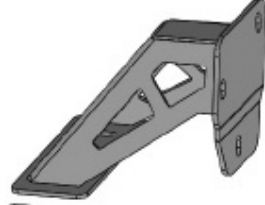

Rear Bumper LT
Part #200357917
Qty. 1

Sections 2 Install Bracket to Frame

Mounting Bracket to Frame Hardware Small Parts Kit

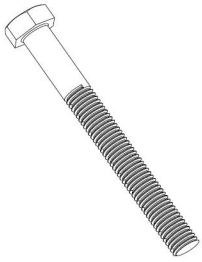

12mm x 110mm Bolt
Part #3002397
Qty. 2

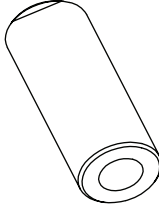

Spacer Tube
Part # 200357346
Qty 2

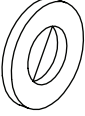

12mm Flat Washer
Part # 3000333 Qty
4

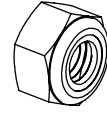

12mm NyLock Nut
Part # 3001418
Qty 2

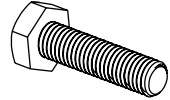

10mm 40mm
Nut Part #
3002724 Qty 4



10mm Lock
Washer Part #
3000160 Qty 4



10mm Washer
Part #
3000318 Qty 4



Installation Instructions Bestop Gladiator Rock Rail

Vehicle Application:
Jeep® Gladiator 2020 - current
Part Number 44963

Parts List

Sections 4 Rock Rail Attachment Hardware Kit

Rock Rail to Mounting Bracket Hardware Small Parts Kit

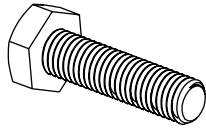

12mm x 40mm Bolt
Part # 3002822
Qty 6

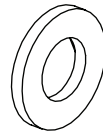

12mm Flat Washer
Part # 3000333
Qty 12

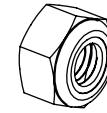

12mm NyLock Nut
Part # 3001418
Qty 6

Sections 5 Rock Rail Attachment Hardware Kit (cont.)

Rock Rail to Bumper Hardware Small Parts Kit

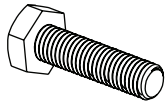

M10x25mm Bolt
Part #3002689
Qty. 4



M10 Lockwasher
Part #3000160
Qty. 4



M10 Flat Washer
Part #3000318
Qty. 4



M10 Nut Plate
Part #200351655
Qty. 2
(From Bestop Bumper Kit)
Not Needed if installed to OEM
Plastic Bumpers

Tools

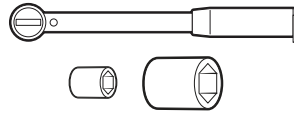

Socket Wrench
8mm Socket
16mm Socket

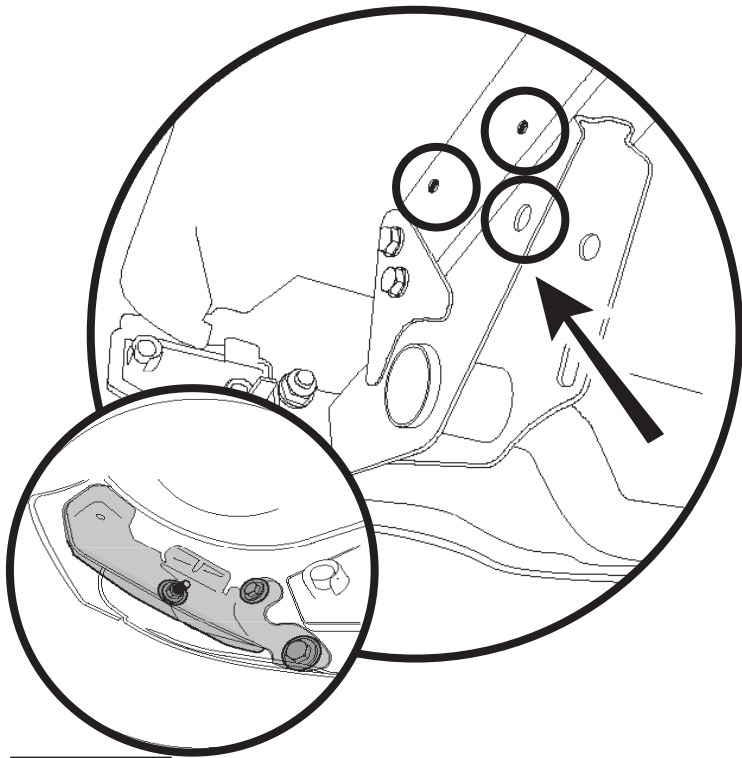

Step 1

If you are installing the RockRail with OEM Plastic Bumpers, Remove the Outer Corner Reinforcement Bracket shown above.

Make sure the Frame Holes are free from hardware, and this frame section is ready for the bracket to be mounted.

Repeat on both sides.

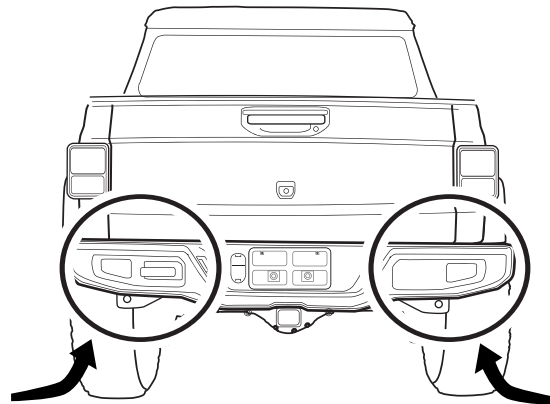

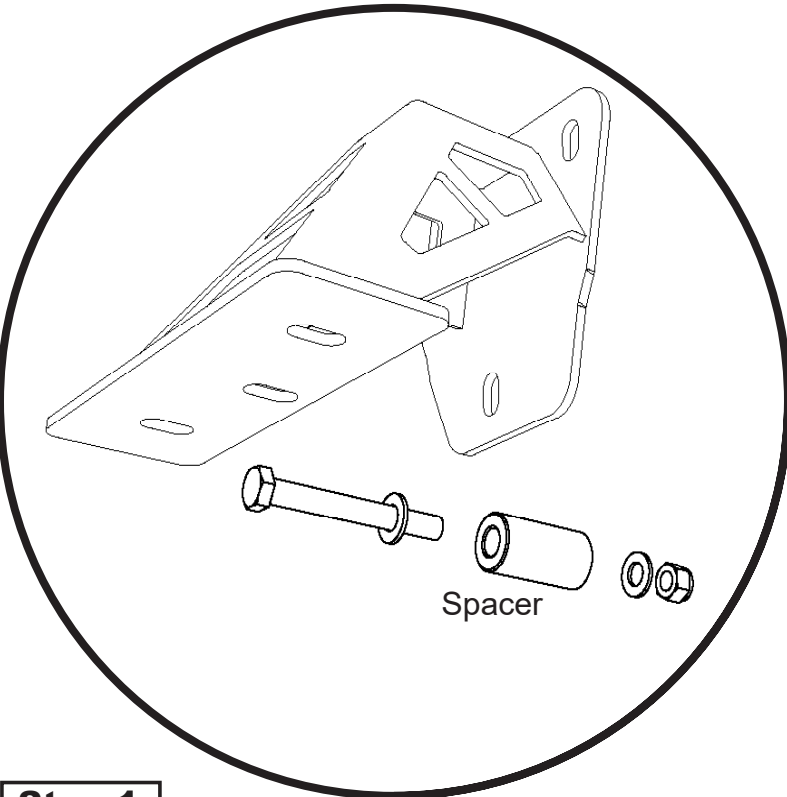

Step 1

NOTE:

Some vehicles will have a spacer welded into place, on the Towbar mount. If there is not a welded spacer, make sure to use the provided spacer from the kit. Have the head of the bolt facing outwards. Repeat on both sides.

Hardware



12mm x 110mm Bolt
Part #3002397
Qty. 2



Spacer Tube
Part # 200357346
Qty 2



12mm Flat Washer
Part # 3000333
Qty 4



12mm NyLock Nut
Part # 3001418
Qty 2

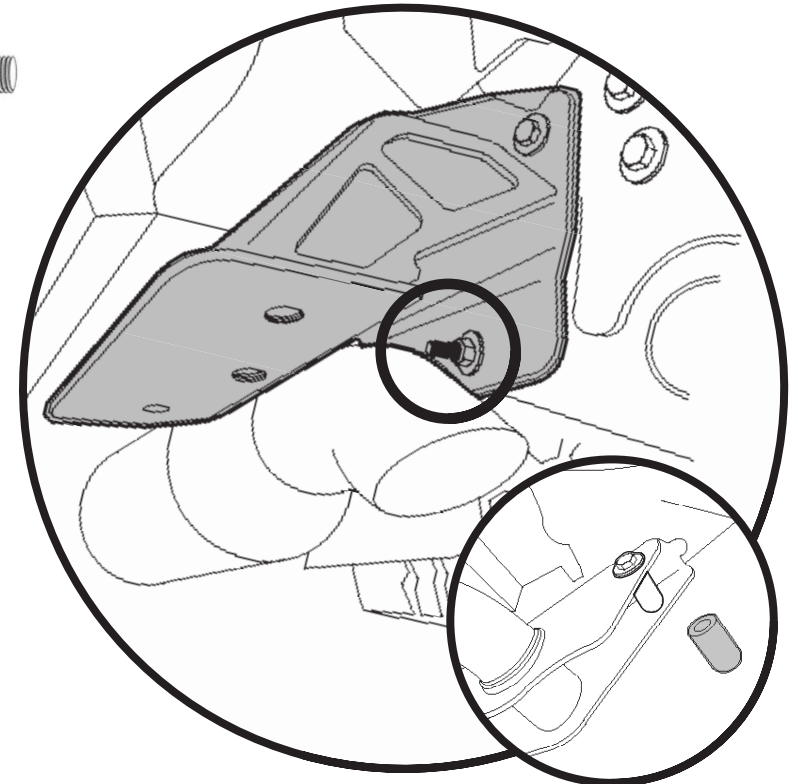

Step 2

Loosely install the hardware and spacer as show above.

The Spacer Tube (200357346) must go between the plates in the TowBar. This will enhance the strength of the assembly

Make sure to place one washer (3000333) on both the Bolt (3002397) head, and under the nut (3001418).

Do Not tighten yet.

Tools

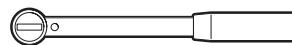

Socket Wrench
16mm Socket
Socket



10mm - 16mm - 18mm
Wrenches

Hardware

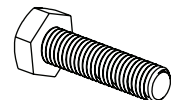

10mm x 40mm Hex Bolt
Part # 3002724
Qty 4



10mm Lock Washer
Part # 3000160
Qty 4



10mm Flat Washer
Part # 3000318
Qty 4

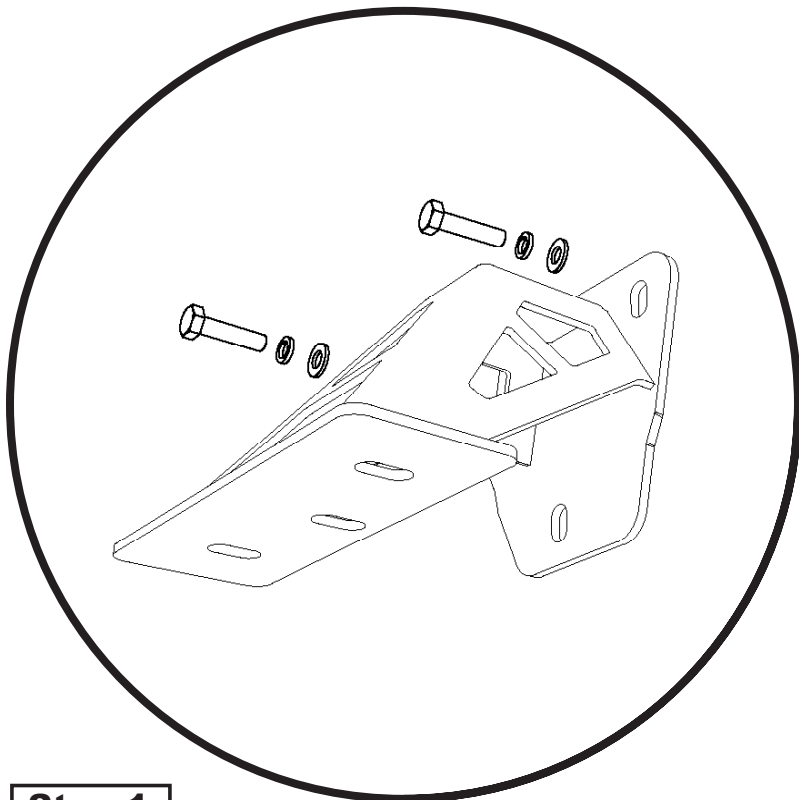

Step 1

Install the remaining hardware through the Mounting Bracket, and into the frame as shown.

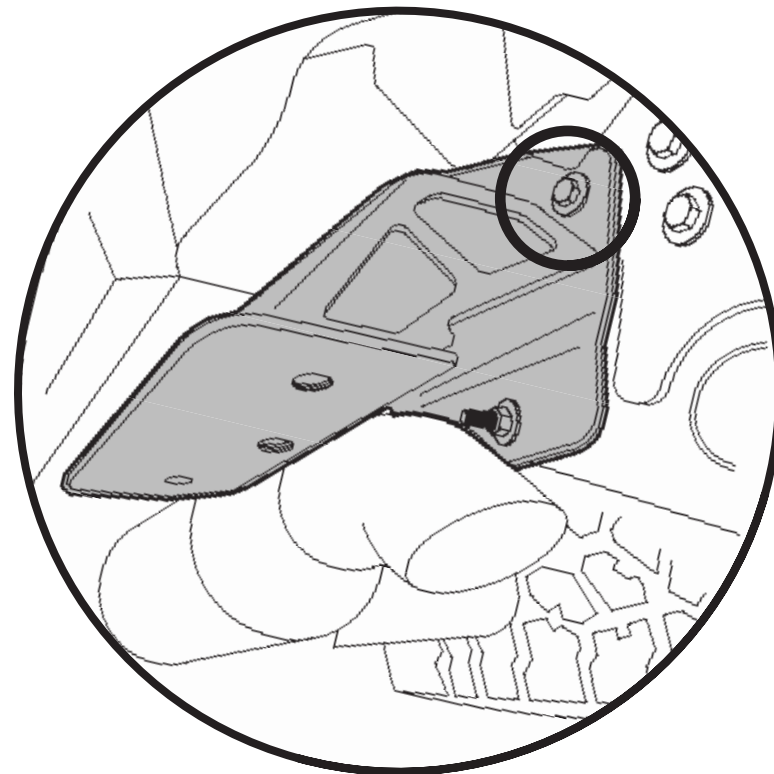

Step 2

Remove the bolt the oem bolt that is circled.

Loosely install the hardware as show above.

Stack up the Hex Bolt (3008127) with a Lockwasher (3008107) and a Flat Washer (3000325)

Do Not tighten yet.

Tools

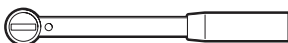

Socket Wrench
16mm Socket
Socket

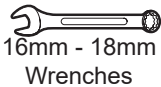

16mm - 18mm
Wrenches

Tools

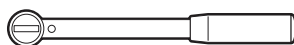

Socket Wrench
8mm Socket
16mm Socket

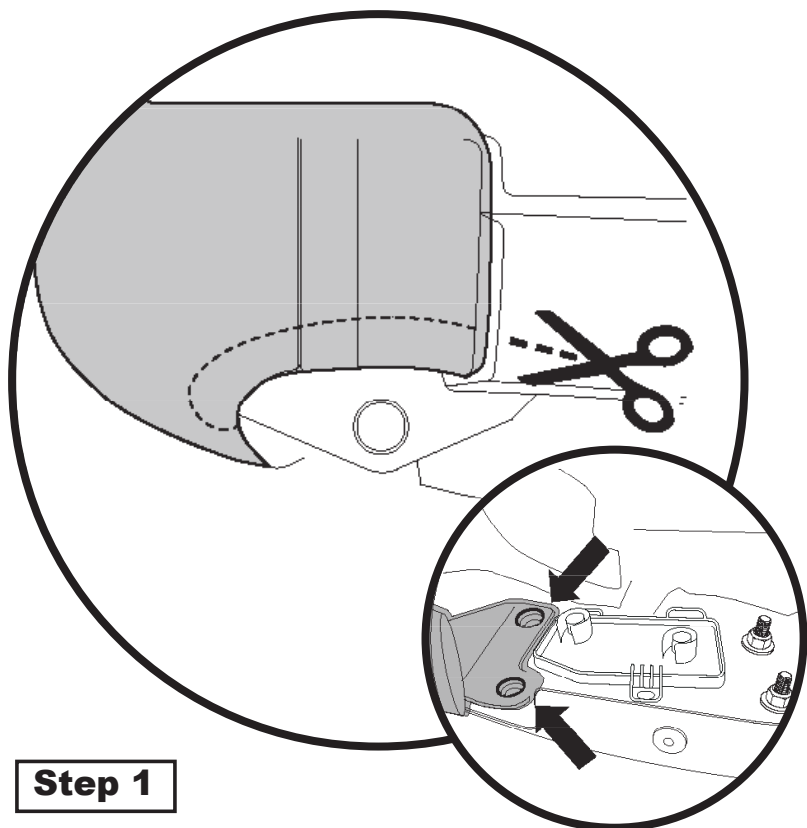

Step 1

If you are installing the RockRail with OEM Plastic Bumpers, test fit the Rock Rail and trim the least amount needed.

Rock Rail will line up to the Bracket Flange, and to the holes from the Outer Corner Reinforcement Bracket previously removed.

Use the corner metal bracket of the oem bumper as a templet.

Repeat on both sides.

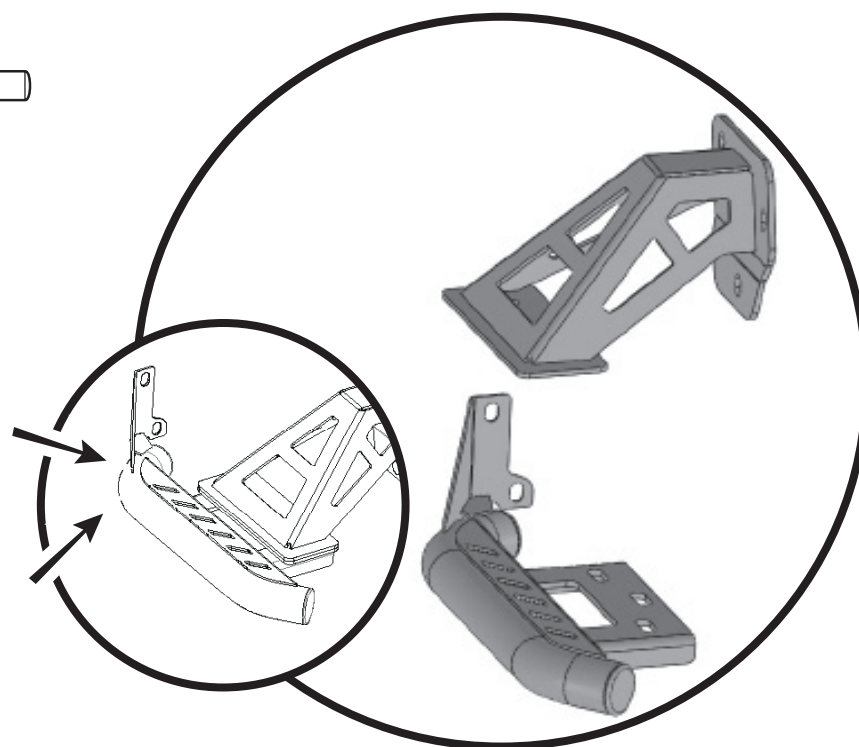

Step 2

If There should be no interference, and have enough space (1/4 inch) to allow for the Rubber Edge Trim to be applied if you chose.

Apply Edge trim to plastic bumper for a finished look at your discretion.

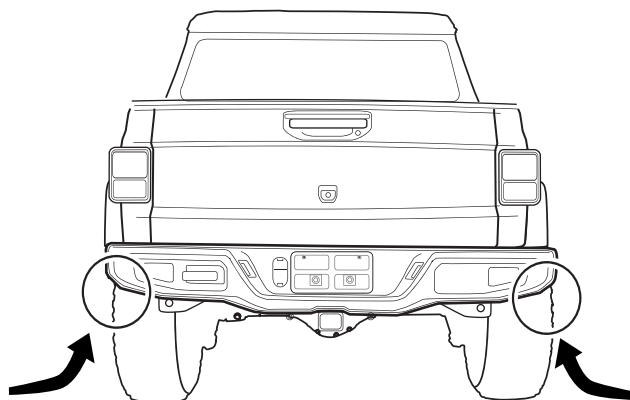

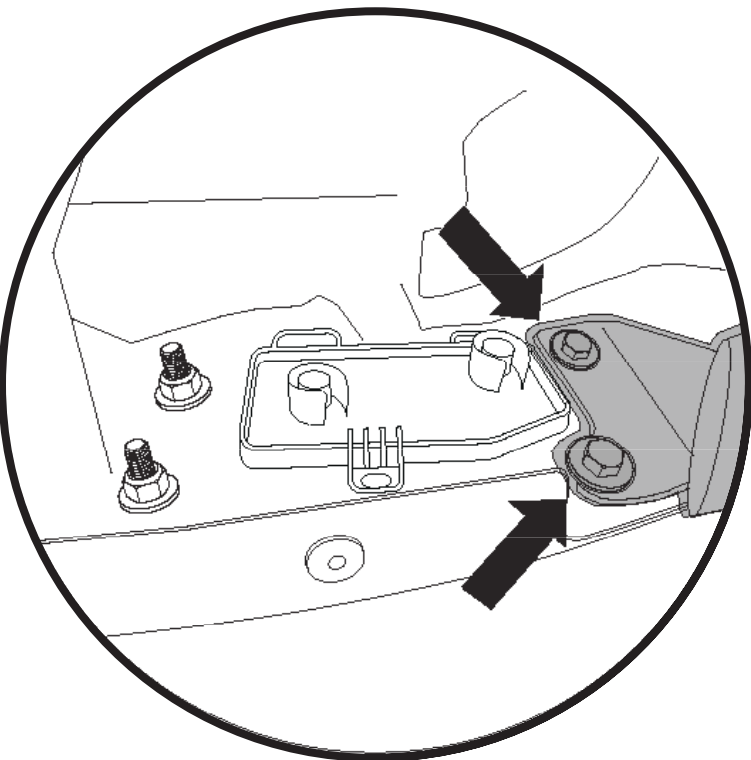

Step 1

For all OEM bumper applications:

Bestop Recommends only using the properly engineered new hardware provided in the parts kit.

Loosely install two (2) M10 Bolts (3002689), with Lock Washer, 3000160, and Flat Washer (3000318)

Hardware

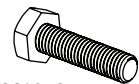

M10x25mm Bolt
Part #3002689
Qty. 4



M10 Lockwasher
Part #3000160
Qty. 4



M10 Flat Washer
Part #3000318
Qty. 4



M10 Nut Plate
Part #200351655
Qty. 2
(From Bestop Bumper Kit)
Not Needed if installed to OEM
Plastic Bumpers

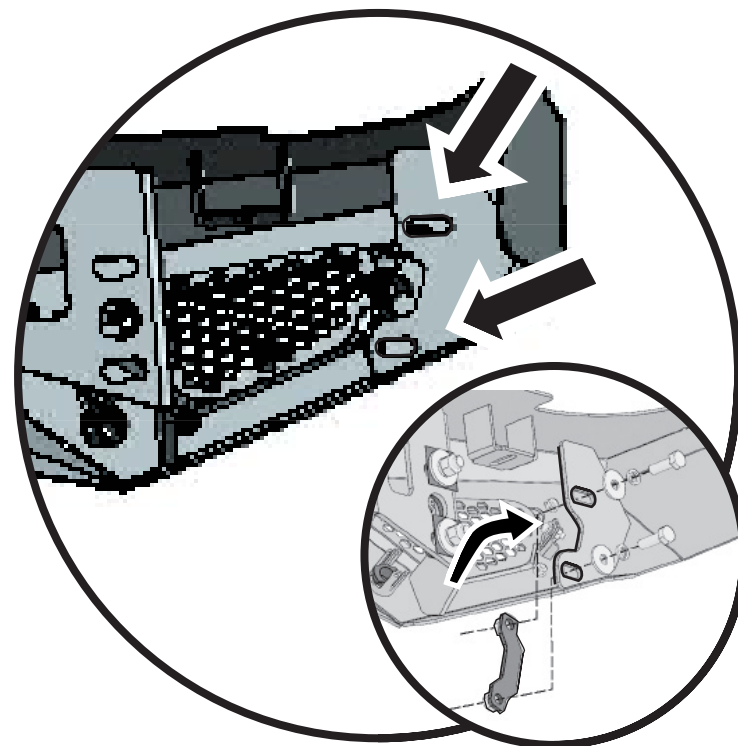

Step 2

For the Bestop Rear Bumper applications:

Use the Provided Bestop M10 Nut Plate (200351655) from the bumper kit, and install this behind the bumper plate as shown.

Loosely install two (2) M10 Bolts (3002689), with Lock Washer (3000160), and Flat Washer (3000318) into the NutPlate.

Tools

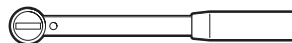

Socket Wrench
16mm Socket
Socket



10mm - 16mm - 18mm
Wrenches

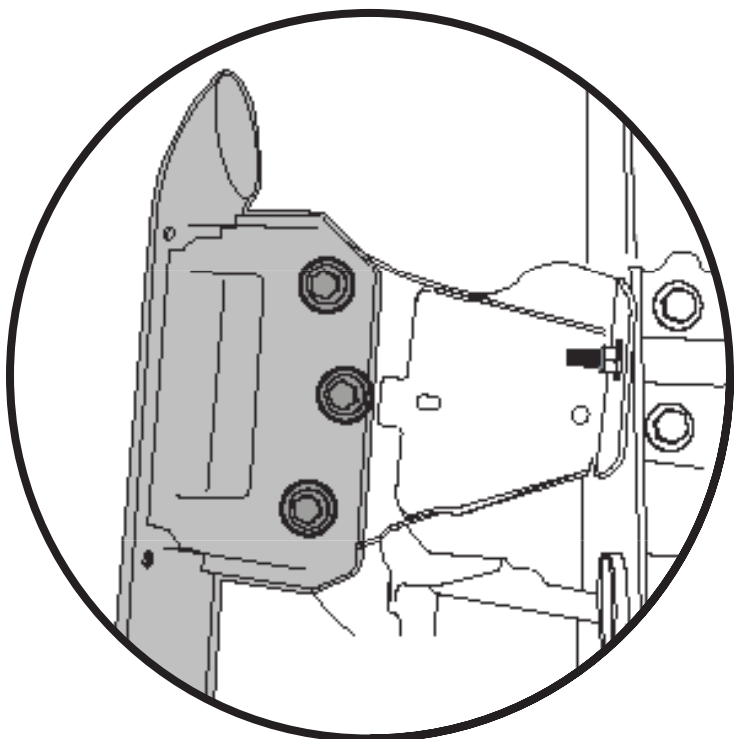

Hardware

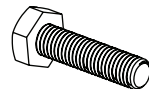

12mm x 40mm Bolt
Part # 3002822
Qty 6



12mm Flat Washer
Part # 3000333
Qty 6



12mm NyLock Nut
Part # 3001418
Qty 6

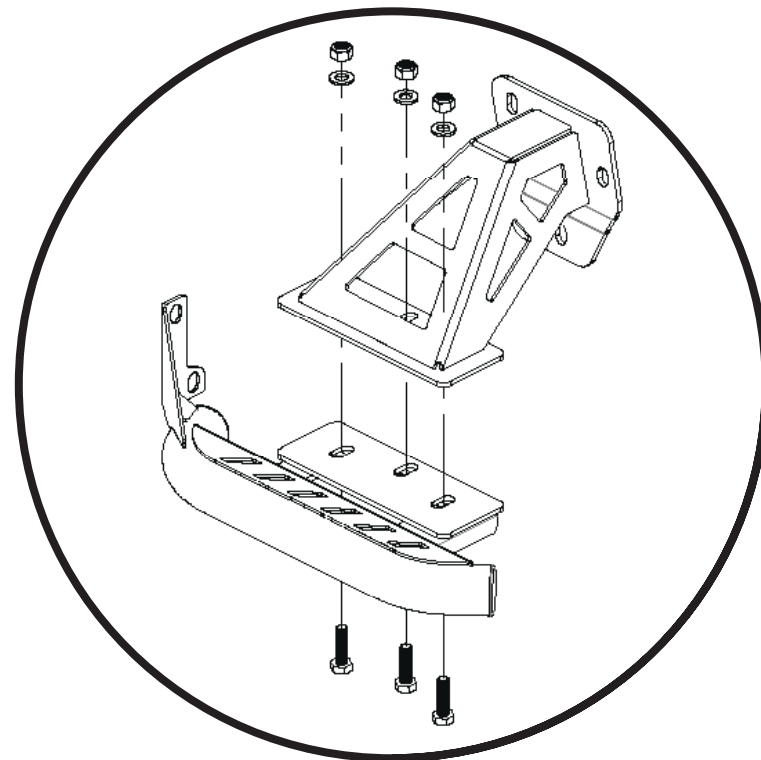

Step 1

For the OEM bumper applications:

Once the Bumper end of the Rock Rail is in position, you can install the Rail to the Frame Mounting Bracket previously installed. Use the OEM hardware or the Bestop Kit hardware, show above.

Step 2

For the Bestop Rear Bumper applications:

Once the Bumper end of the Rock Rail is in position, on the Bestop Rear Bumper, you can install the Rock Rail to the Frame Mounting Bracket previously installed. Use the Bestop Kit hardware, as show above.

Tools

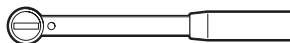

Socket Wrench
16mm Socket
Socket



10mm - 16mm - 18mm
Wrenches

From the Bottom side, place the M12 hex bolt (3002822) through the holes in Rock Rail, and the matching holes in the Bracket, then place the Washer (3000333), and install the M12 Nylock Nut (3001418).

Now that all parts are in position;

Torque all hardware to 75 Nm (55 Ft Lbs)



Installation Instructions Bestop Gladiator Rock Rail

Vehicle Application:
Jeep® Gladiator 2020 - current
Part Number 44963

WHAT BESTOP WARRANTS

Subject to the terms and conditions of sale, including any terms and conditions set forth by Bestop, Inc. (“Bestop” or “us” or “we”) in our then-current terms of sale on our website (collectively, the “Terms”), Bestop represents and warrants that: the covered products listed in the “Covered Products and Warranty Periods” section (a “Product”) will substantially be free from defects in materials and workmanship for the specified warranty periods set forth in that section.

THE WARRANTY IS LIMITED AND CONDITIONAL

This warranty applies to the original purchaser of the Product only. The warranty is valid only as long as the original retail purchaser owns the vehicle upon which the Product is installed. The warranty expires should the Product be removed from the original vehicle or if the original vehicle is transferred to another owner. This warranty is not transferable or assignable. The warranty does not apply to Product bought from auction-style or price-bid websites.

THE LIMITED WARRANTY AND STATED REMEDIES ARE SOLE AND EXCLUSIVE AND IN LIEU OF ALL OTHER WARRANTIES AND REMEDIES, AND COMPANY EXPRESSLY DISCLAIMS ALL IMPLIED OR STATUTORY OR OTHER WARRANTIES, INCLUDING WITHOUT LIMITATIONS WARRANTIES OF MERCHANTABILITY, NON-INFRINGEMENT OR FITNESS FOR A PARTICULAR PURPOSE. IN NO EVENT WILL COMPANY BE LIABLE FOR ANY SPECIAL, INCIDENTAL, CONSEQUENTIAL, PUNITIVE, INDIRECT OR EXEMPLARY DAMAGES OF ANY KIND, INCLUDING LOST PROFITS OR REVENUE, HOWEVER CAUSED, WHETHER FOR BREACH OR REPUDIATION OF CONTRACT, TORT, BREACH OF WARRANTY, NEGLIGENCE, OR OTHERWISE, WHETHER OR NOT COMPANY WAS ADVISED OF THE POSSIBILITY OF SUCH LOSS OR DAMAGES.

Some states do not allow exclusion or limitation, so this may not apply to you. This warranty gives you specific legal rights, and you may have other rights which vary from state to state.

EXCLUSIONS TO THE WARRANTY

The Limited Warranty excludes, and Bestop is not liable in any way for any warranty claims, damages, or defects related to:

- Misuse, abuse, accidents, vandalism, negligence, fire, or improper installation or modification, or improper or inadequate maintenance;
- Failure to comply with any Product documentation, Bestop instructions, or applicable law or regulations; use in extreme conditions
- Force Majeure including but not limited to, earthquake, hurricane, tornado, flooding, or other disasters natural or man-made, civil unrest, strikes, declared or undeclared war, or lack of performance by, or discontinued product of, supply chain partners whose products, software, operations or management is beyond the control of Bestop;
- Damage resulting in breakage (including without limitation, spontaneous breakage, accidental breakage or breakage by any other means) of a Product or any component part;
- Damage to vinyl windows due to misuse, or cracking due to varying weather conditions.

YOUR SOLE REMEDY

During the applicable warranty period, Bestop shall, at its option, either repair or replace any Product that it confirms, in its discretion, is non-compliant with the warranties herein. Bestop will not pay for labor charges associated with installation or removal of the Product. Should a specific Product be discontinued, Bestop may, at its option, replace the discontinued Product with a current product or like product.

Please retain your proof of purchase. Original proof of purchase for the Product must accompany any warranty claim. If you have a warranty claim, first you must email Bestop Customer Service at csbestop@bestop.com for instructions. All claims must be emailed to csbestop@bestop.com within 30 days of discovery of a defective Product, but in no event later than thirty days after the end of the applicable Warranty Period (the “Warranty Notice Period”). Warranty claims made after the Warranty Notice Period are null and void and Bestop shall have no responsibility with respect to such claims.

THIS SECTION SETS FORTH BESTOP'S SOLE OBLIGATION & YOUR SOLE REMEDY WITH RESPECT TO ANY DEFECTS OR OTHER PRODUCT ISSUE. ANY PRODUCTS REPLACED UNDER TERMS OF THIS WARRANTY WILL BE COVERED UNDER TERMS & BALANCE OF THE DURATION OF THE ORIGINAL LIMITED WARRANTY FOR SUCH PRODUCT.



Installation Instructions Bestop Gladiator Rock Rail

Vehicle Application:
Jeep® Gladiator 2020 - current
Part Number 44963

COVERED PRODUCTS AND WARRANTY PERIODS: The warranty time periods are as follows for Products manufactured by Bestop:

BESTOP® LIMITED LIFETIME WARRANTY

Trektop® Pro Twill Fabric Top Sunrider® for Hardtop Twill Fabric Top
Trektop® NX Glide Twill Fabric Top Replace-a-Top™ Twill Fabric Top
Trektop® NX Twill Fabric Top Supertop® NX Twill Fabric Top
EZFold™ Soft Tonneaus Floor & Cargo Liners
ZipRail™ Soft Tonneaus Pet Barriers
EZRoll™ Soft Tonneaus

BESTOP® 5-YEAR LIMITED WARRANTY

Trektop® NX Glide™ Top (non-Twill) Sunrider® for Hardtop (non-Twill) Replace-a-Top™ Top (non-Twill) Trektop® NX Top (non-Twill)
Sailcloth Replace-a-Top™ Supertop® NX Top (non-Twill)
Tigertop™ and Halftop™ Supertop® Classic Soft Top Sunrider® Complete Soft Top Supertop® for Truck
EZ Fold Hard Tonneau

BESTOP® 3-YEAR/100K MILES LIMITED WARRANTY

Powerboard® & Powerboard® NX
Trekstep®, Side Mount
Trekstep®, Rear Mount

BESTOP® 3-YEAR LIMITED WARRANTY

Pavement Ends Sprint Top

BESTOP® 2-YEAR LIMITED WARRANTY

Trektop® Classic Soft Top
RoughRider™ Soft Storage

BESTOP® 1-YEAR LIMITED WARRANTY

All other Bestop® & Pavement Ends™ products not specified above.

For further information or request for warranty work, please contact:

Bestop Inc. Customer Service
Toll-Free: (800)845-3567
E-mail: csbestop@Bestop.com
Website: www.Bestop.com